



C&D VRLA Batteries Extended Run Time for Small UPS Machines

Small UPS machines, in the range of 400 to 2500 VA, are typically used to provide standby power for one or more personal computers in the event of a commercial power outage. These UPS machines will typically have an internal battery with a 3 to 5 year life expectancy and which is sized to provide from 5 to 45 minutes of standby operating time. The user may operate at a location that experiences frequent commercial power outages of long duration, perhaps even daily, and they may want to use the UPS as an alternative power source since there is no backup generator.

The solution? Add a battery of the same voltage in parallel. Naturally, the additional parallel battery will be external to the UPS machine and the most obvious solution is as shown in Figure 1.

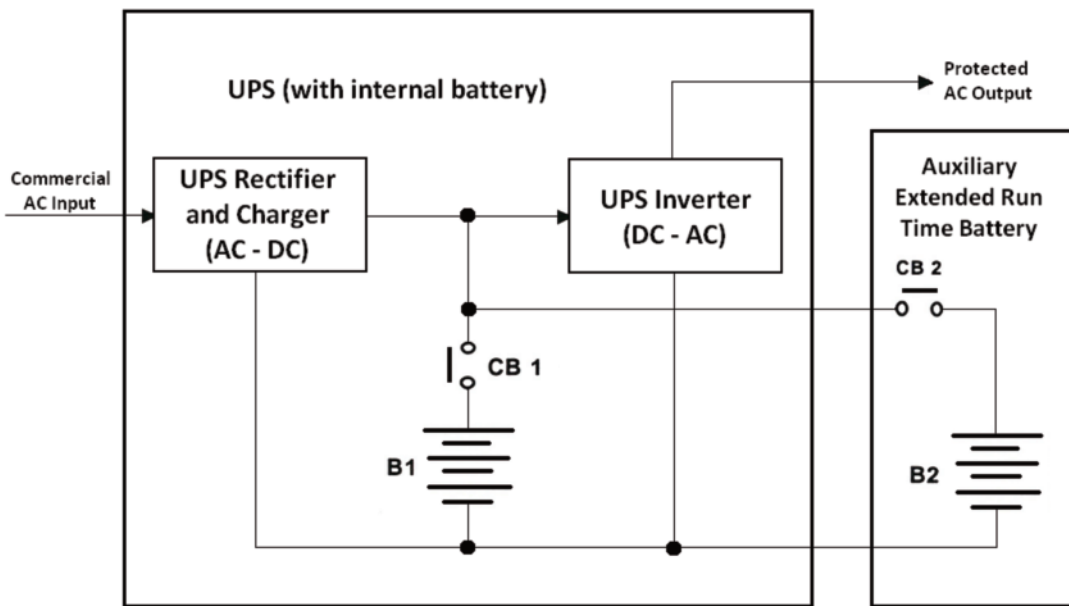

Figure 1 - Auxiliary Battery

When adding an external battery there are several issues to be considered when determining the actual configuration. These would include:

1. The capability of the UPS electronics to operate for extended periods without overheating.
2. The capability of the UPS charging circuit to recharge the additional battery in the desired recharge time.
3. Isolation of the additional battery from the UPS internal battery to prevent a shorted cell in one string from affecting the other string.
4. Battery to UPS connector and wire size as related to the anticipated discharge and recharge current of the additional battery.
5. Appropriate ventilation of the additional battery in the external enclosure.

The configuration as shown in Figure 1 is certainly the easiest to implement, however, it does assume that the UPS rectifier has the ampere output capability to power the inverter, recharge the internal battery and in addition, recharge the auxiliary battery. For this configuration and that of Figure 2, the UPS rectifier should have a minimum reserve current of 2 amperes per 100 ampere-hours of capacity of the auxiliary battery. This minimum reserve current should provide for recharge of the auxiliary battery within a 72-hour period.

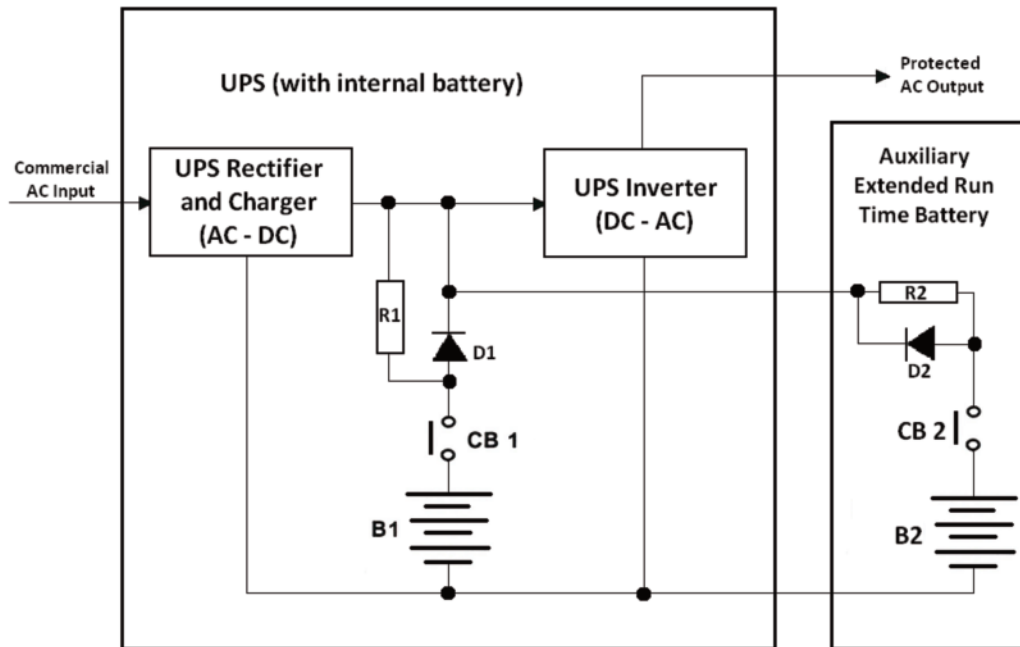

Figure 2 - Auxiliary Battery with Charging Current Limiting Resistors

If the current capability of the UPS internal rectifier is marginal, the recharge current to the batteries can be limited with resistors (R1 & R2) as noted in Figure 2. For example, assume a UPS rectifier had only 2 amperes available for charging a self contained 10 ampere-hour capacity battery and that a 40 ampere-hour battery were being added in parallel as an external battery. In this case the limited available charging current should be divided between the two batteries in proportion to their capacities. In this case, 1/5 of the recharge current (0.4 amperes) should be supplied to the internal 10 ampere-hour battery and 4/5 or the recharge current (1.6 amperes) to the external 40 ampere-hour battery. The current limiting resistor values would be calculated as that required to limit the inrush current to the desired value when the full charging voltage is applied to the discharged battery while at it's open circuit value. The value of the resistors heat dissipation capability (wattage) would be simply the product of the voltage drop multiplied by the maximum current ($V \cdot I$) or the maximum current squared multiplied by the resistance ($I^2 R$).

For example, assume the charging voltage is 2.3 volts per cell for a 24-cell system or 55.2 VDC. The worse case is when the discharged battery open circuit voltage would be 1.96 volts per cell or 47 VDC for a 24-cell system. The internal 10 ampere-hour battery current limiting resistor values would be calculated as:

$$R1 = (55.2 - 47) \text{ VDC} / 0.4 \text{ amperes}$$

$$R1 = 20.5 \text{ Ohms}$$

$$W_{R1} = (55.2 - 47) \text{ VDC} \times 0.4 \text{ amperes}$$

$$W_{R1} = 3.25 \text{ watts minimum}$$

The external 40 ampere-hour battery current limiting resistor values would be calculated as:

$$R2 = (55.2 - 47) \text{ VDC} / 1.6 \text{ amperes}$$

$$R2 = 5.1 \text{ Ohms}$$

$$W_{R2} = (55.2 - 47) \text{ VDC} \times 1.6 \text{ amperes}$$

$$W_{R2} = 13.1 \text{ watts minimum}$$

During discharge the batteries will supply power through the diodes D1 and D2 thus eliminating the voltage drop that would otherwise have occurred through R1 and R2.

While other approaches to the current limiting feature are possible, use of the resistor is perhaps the simplest and least expensive, however, it will increase the recharge time. Also, if resistive current limiting is employed, the heat-producing resistor should not be mounted near the battery.

Although the configuration of Figure 1 and 2 will work, they have one significant common deficiency: they do not provide for mutual isolation of the two battery systems. As a result, if there should be a shorted cell in one battery it will discharge the other battery connected in parallel. This can be a significant problem especially when the two-battery systems have different life expectancies or use histories. This deficiency can be corrected as shown in Figure 3.

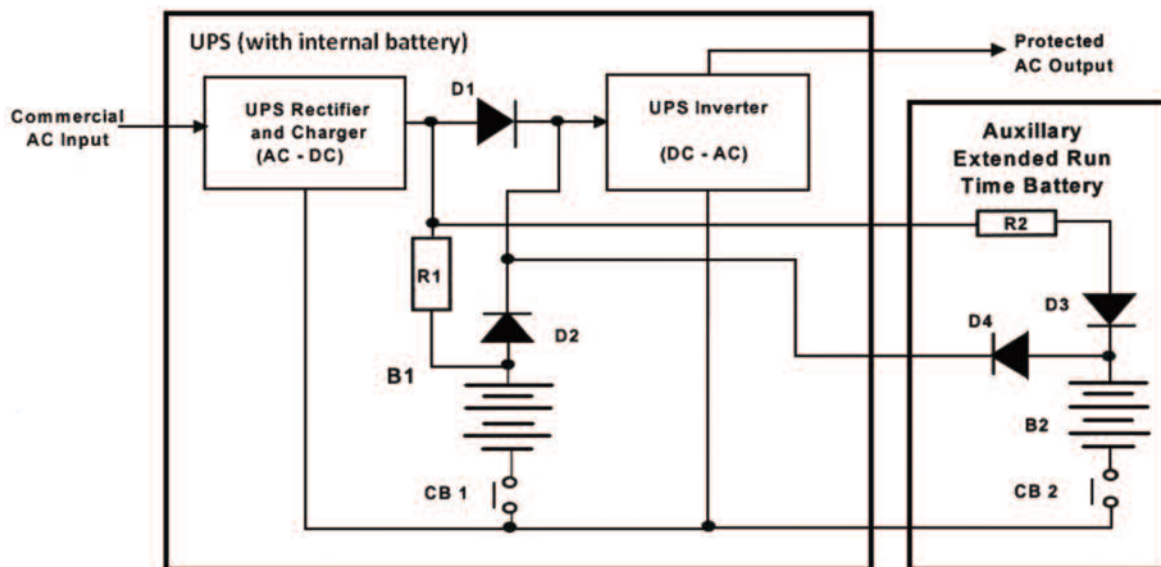

Figure 3 - Auxiliary Battery with Charging Current Limiting Resistors and Diode Isolation

In this configuration the resistors R1 and R2 limit the charging current to each of the two batteries as they did in Figure 2 however the action of D1, D2 and D4 prevent a short in either battery from discharging the other battery.

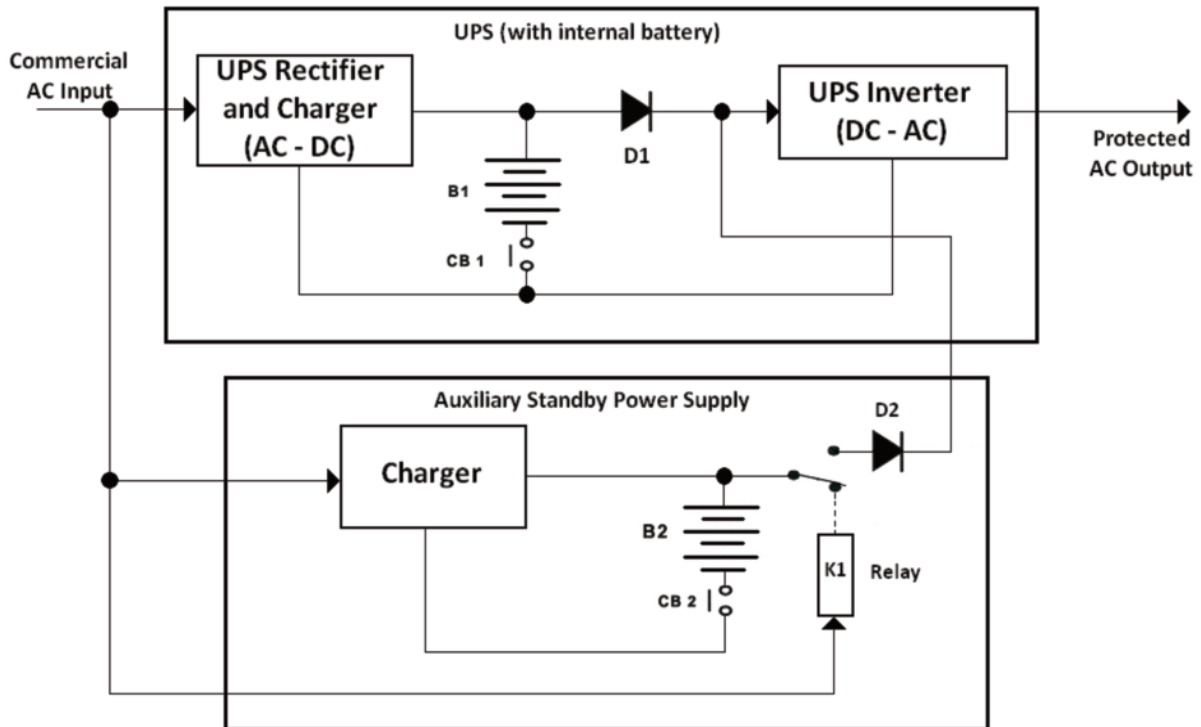

Figure 4 - Auxiliary Battery and Charging System

When the UPS internal charger does not have sufficient ampere capability to recharge the auxiliary battery in a reasonable time it will be necessary to include an auxiliary charger in the external package. This configuration would be similar to that shown in Figure 4. As shown, using the normally closed contacts of the commercial power relay (or a solid state switch), the auxiliary battery and charger are completely isolated from the UPS until such time as there is a commercial power failure. Upon the commercial power failure the relay K1 will deenergize and the normally closed (NC) contacts will close placing the auxiliary battery in parallel with the UPS internal battery.

The commercial power relay K1 can be omitted if the UPS internal battery charging voltage is adjusted to a value slightly higher (e.g. 2.3 v/c) than that used on the auxiliary battery (e.g. 2.25 v/c). In this situation diode D2 would be reverse biased until such time that there was a commercial power failure when it would be forward biased and route it's share of the load current to the UPS inverter. The arrangement of diodes D1 and D2 also isolate the two battery systems preventing a shorted cell in one string from affecting the other string. This is perhaps the most simple of all the configurations however, the relative settings of the chargers output voltages is critical.

Table 1 identifies the approximate 20 hour rated ampere hour capacity of the battery required to provide the noted operating time for UPS systems of the noted VA rating, power factor (pf), DC-AC inverter efficiency and DC buss voltage.

When adding parallel strings of batteries of the same voltage, each of the strings should be separately cabled to the common tie point and should include individual string overcurrent protection.

| UPS-VA Rating @ 0.8 p.f. | DC Buss Voltage | Assumed AC-DC Efficiency | Battery Watts | Battery Watts per Cell | Approximate Hours Operation Per Rated Battery Ampere-Hour Capacity | | | |
|--------------------------|-----------------|--------------------------|---------------|------------------------|--|---------|---------|---------|
| | | | | | 1 Hour | 2 Hours | 3 Hours | 4 Hours |
| 500 | 12 | 65% | 615.4 | 102.6 | 85 | 150 | 200 | 250 |
| | 24 | 65% | 615.4 | 51.3 | 43 | 75 | 100 | 125 |
| | 36 | 70% | 571.4 | 31.7 | 26 | 46 | 62 | 77 |
| | 48 | 75% | 533.3 | 22.2 | 18 | 33 | 43 | 54 |
| | 72 | 75% | 533.3 | 14.8 | 12 | 22 | 29 | 36 |
| | 120 | 80% | 500.0 | 8.3 | 7 | 12 | 16 | 20 |
| 1000 | 12 | 65% | 1230.8 | 205.1 | 170 | 300 | 400 | 500 |
| | 24 | 65% | 1230.8 | 102.6 | 85 | 150 | 200 | 250 |
| | 36 | 70% | 1142.9 | 63.5 | 53 | 93 | 124 | 155 |
| | 48 | 75% | 1066.7 | 44.4 | 37 | 65 | 87 | 108 |
| | 72 | 75% | 1066.7 | 29.6 | 25 | 43 | 58 | 72 |
| | 120 | 80% | 1000.0 | 16.7 | 14 | 24 | 33 | 41 |
| 1500 | 12 | 65% | 1846.2 | 307.7 | 255 | 450 | 600 | 750 |
| | 24 | 65% | 1846.2 | 153.8 | 128 | 225 | 300 | 375 |
| | 36 | 70% | 1714.3 | 95.2 | 79 | 139 | 186 | 232 |
| | 48 | 75% | 1600.0 | 66.7 | 55 | 98 | 130 | 163 |
| | 72 | 75% | 1600.0 | 44.4 | 37 | 65 | 87 | 108 |
| | 120 | 80% | 1500.0 | 25.0 | 21 | 37 | 49 | 61 |
| 2000 | 12 | 65% | 2461.5 | 410.3 | 340 | 600 | 800 | 1000 |
| | 24 | 65% | 2461.5 | 205.1 | 170 | 300 | 400 | 500 |
| | 36 | 70% | 2285.7 | 127.0 | 105 | 186 | 248 | 310 |
| | 48 | 75% | 2133.3 | 88.9 | 74 | 130 | 173 | 217 |
| | 72 | 75% | 2133.3 | 59.3 | 49 | 87 | 116 | 144 |
| | 120 | 80% | 2000.0 | 33.3 | 28 | 49 | 65 | 81 |
| | 144 | 85% | 1882.4 | 26.1 | 22 | 38 | 51 | 64 |
| 2500 | 12 | 65% | 3076.9 | 512.8 | 425 | 750 | 1000 | 1250 |
| | 24 | 65% | 3076.9 | 256.4 | 213 | 375 | 500 | 625 |
| | 36 | 70% | 2857.1 | 158.7 | 132 | 232 | 310 | 387 |
| | 48 | 75% | 2666.7 | 111.1 | 92 | 163 | 217 | 271 |
| | 72 | 75% | 2666.7 | 74.1 | 61 | 108 | 144 | 181 |
| | 120 | 80% | 2500.0 | 41.7 | 35 | 61 | 81 | 102 |
| | 144 | 85% | 2352.9 | 32.7 | 27 | 48 | 64 | 80 |

Table 1 - Ah Battery Capacity for Specified Run Time

C&D TECHNOLOGIES, INC.

1400 Union Meeting Road
P.O. Box 3053 • Blue Bell, PA 19422-0858
(215) 619-2700 • Fax (215) 619-7899 • (800) 543-8630
customersvc@cdtechno.com
www.cdtechno.com

Any data, descriptions or specifications presented herein are subject to revision by C&D Technologies, Inc. without notice. While such information is believed to be accurate as indicated herein, C&D Technologies, Inc. makes no warranty and hereby disclaims all warranties, express or implied, with regard to the accuracy or completeness of such information. Further, because the product(s) featured herein may be used under conditions beyond its control, C&D Technologies, Inc. hereby disclaims all warranties, either express or implied, concerning the fitness or suitability of such product(s) for any particular use or in any specific application or arising from any course of dealing or usage of trade. The user is solely responsible for determining the suitability of the product(s) featured herein for user's intended purpose and in user's specific application.